

EXPELLO Electronic Drain Valve



Expello Electronic Drain Valve

The Expello Electronic Drain Valve provides increased durability and reliability for constant protection from build-up of harmful contaminants in air tanks on trailers, buses, trucks and other vehicles.

The Expello Electronic Drain Valve expels contaminants every five minutes of vehicle operation with a powerful one-second blast of air. The electronic controls and 15-watt heater provide all weather, year round protection.

The Expello Electronic Drain Valve's corrosion resistant construction ensures maintenance-free protection over the long haul. Once installed in place of your manual drain petcock, the Expello Electronic Drain Valve's straight-through contaminant flow and self-cleaning design provides long-term air tank draining without daily checks. Brakes and other air-operated systems consistently receive cleaner, dry air when contaminants are removed from air tanks, thus extending component service life.

The Expello Electronic Drain Valve consists of a powerful heavy-duty coil, a long-life timer with a built-in surge protection and a 15-watt thermostatically controlled heater. The valve is protected by internal fuses. All components of the Expello Electronic Drain Valve are covered by a three – year unlimited mileage warranty.

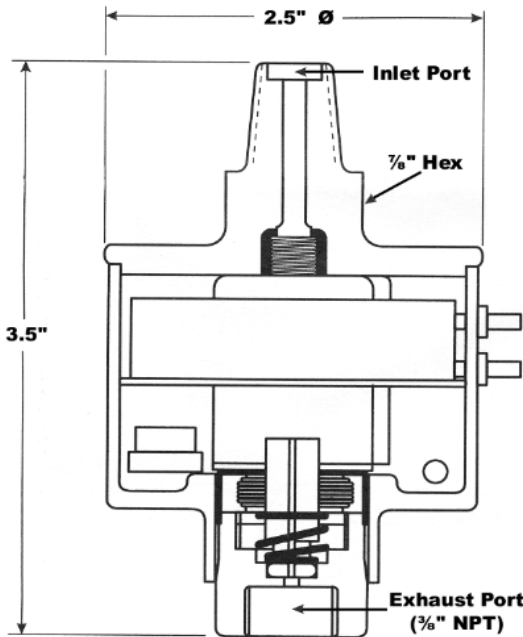

SPECIFICATIONS	
Operating Current:	Direct Current (DC)
Operating Voltage:	12 VDC or 24VDC
Heater Switch-On/Off-Point:	50° F / 10° C
Heater Watts:	15 Watts
Heater Amp Draw:	1.2 Amps (12 V) or 0.6 Amps (24 V)
Energized Coil Amp Draw:	2.3 Amps (12 V) or 0.9 Amps (24 V)
Timer Amp Draw:	200 Milliamps
Maximum Operating Pressure:	200 PSI / 13.8 Bar
Thermal Range of Operation:	-67° F to 180° F / -55° C to 82° C
Weight:	Approx. 1.2 Pounds / .55 Kilograms
Height and Diameter:	3.525 In. x 2.590 In. / 89.5 mm x 65.8 mm

Part Number	Description - Valves	Inlet Size
995111	Electronic Valve, 12 Volt Heated	1/4" NPT
995112	Electronic Valve, 24 Volt Heated	1/4" NPT
995113	Electronic Valve, 12 Volt Heated	3/8" NPT
995114	Electronic Valve, 24 Volt Heated	3/8" NPT
995115	Electronic Valve, 12 Volt Heated	1/2" NPT
995116	Electronic Valve, 24 Volt Heated	1/2" NPT

EXPELLO Electronic Drain Valve

Easy Installation Instructions

1. With vehicle not running, depressurize the air system. This can be accomplished by slowly opening the manual drain petcock on the air tank to have the Expello Drain Valve installed.

2. If the manual drain petcock is not on the bottom of the tank inspect the tank for the lowest position possible to mount the Expello Drain Valve. After depressurization of the system remove the manual drain petcock valve or the plug in the lowest position and wipe the threaded port clean.

3. Install the Expello Drain Valve in the port selected. The Expello Drain Valve should be mounted on the very bottom of the tank. Pipe tape or sealant may be used on the brass threads of the cover to assure a tight seal. Tighten the Expello Drain Valve using only the hex nut on the cover of the valve (7/8" hex.) **Do not tighten using the exhaust port. Be sure not to cover the inlet port of the Expello Drain Valve with the tape or sealant.**

4. Connect the Black wire (ground) to the vehicle system ground first. **Do not use the Expello Drain Valve for a ground.** The frame can be used as a ground, but be sure to make contact with the bare frame. Insulate all exposed connections.

5. Connect the Red wire (power) to the master fuse panel. The ignition "on" switch is recommended. Insulate all exposed connections.

6. Start engine to build system pressure. Listen and feel for air leaks at the tank and Expello Drain Valve connection.

7. Five minutes after the engine is started and system pressure is maintained, a distinct, one-second blast of air will come from the bottom of the Expello Drain Valve. These blasts will continue every five minutes until the voltage to the Expello Drain Valve is removed.

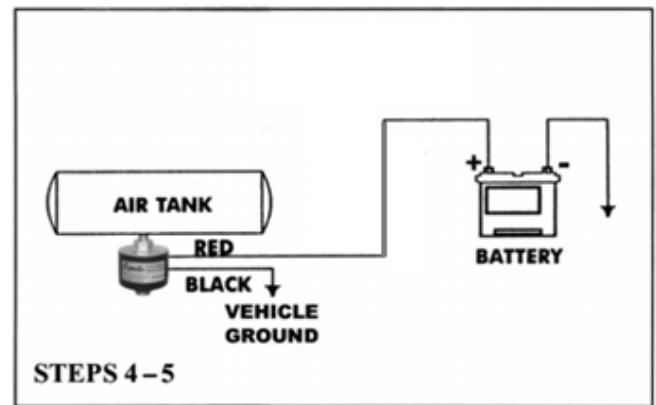
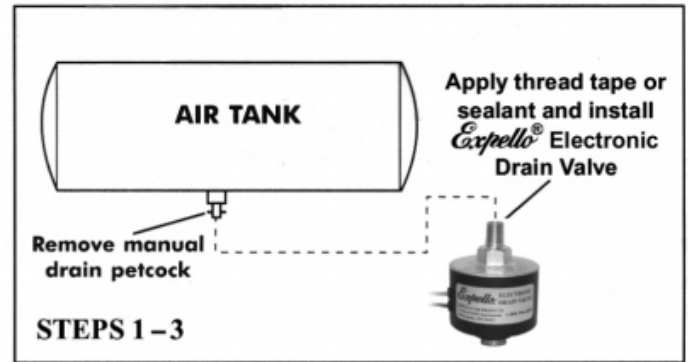

EXPELLO AIR PRODUCTS

A Unit of D&D Instruments

2525 Winter Street NE

Minneapolis, MN 55413

1-800-766-4243

www.ddinstruments.com

Expello®